

SEAMLESS TECHNOLOGY

ELECTRONIC SEAMLESSWEAR KNITTING MACHINE

SM8-TR1 SINGLE JERSEY

SEAMLESS TECHNOLOGY

SM8-TR1 SINGLE JERSEY



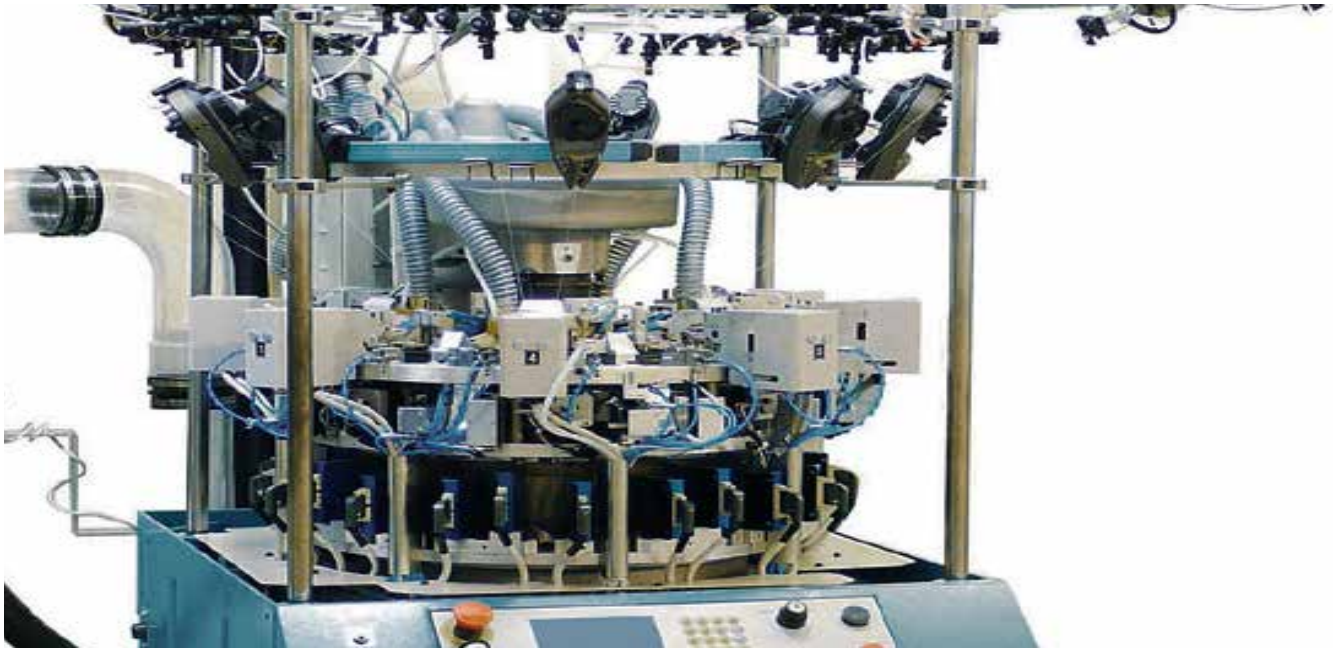

SEAMLESS TECHNOLOGY

SM8-TR1 SINGLE JERSEY

8 Feeds single jersey circular electronic machine available from 14" to 22" dia. with 2 selection points (on three (3) technical ways) for the knitting feeder plus 1 selection point for the production of fishnet or antidrop stitch structures (patented by Santoni). The machine allows knitting of seamless-wear. Swimwear, sportswear, sanitary wear garments.

SEAMLESS TECHNOLOGY

SM8-TR1 SINGLE JERSEY

● DIAMETERS

14" - 15" - 16" - 17" - 18" - 19" - 20" - 21" - 22"

● MACHINE GAUGE

Npi 16 - 20 - 24

● NEEDLES GAUGE

gg 48 and gg 54.

● NUMBER OF FEEDS

8 for any diameter.

● MAXIMUM SPEED

Diameter from 14" speed factor from 1190 (85rpm) when knitting plain jersey.

Diameters from 15" to 22" speed factor 1300 (16" 80rpm) when knitting plain jersey.

Diameters from 14" to 22" speed factor 1000 (16" 60rpm) when knitting fishnet fabric.

● TYPE OF SELECTION

From 16" to 22" - n° 2 + 1 actuators with 16 levels on each feed - For 14" and 15" n.2 +1 actuators with 16 levels on 1st,2nd,3rd,5th,6th,7th feed, n.2 actuators with 16 levels on 4th and 8th feed.

● STRIPPING YARNFINGERS

7 multiposition yarn fingers on each feed (Patented by Santoni) n. 3+4 fingers on the main feed. Optional: (using the 4 extractable cams for plain jersey) from 16" to 22": n.2 yarn fingers per colour on the ground yarn on all 4 feeds; from 14" to 15" n° 2 yarnfingers per color on the ground yarn of 2nd and 6th feed.

● TRAPPER FOR BARE AND COVERED ELASTIC YARN

n° 3 units on each feed.

● DIAL JACKS AND YARN CUTTER

Dial vertical movement driven by step by step motor which allows the height variation of the cutter work.

● SUCTION SYSTEM

By 2 (or 3 according to diam.)suction fans or central system. Inner tube stitch formation diam. 150. Garment transfer tube diam. 100 mm. Air limiting valve with electronic incremental programming.

● STITCH CAMS

Stitch formation adjustment by step motors, independently on each feed, with possibility of loop widening, tightening and shading on the same course (Santoni patent). On board garment sizing, adjustable in both cm and inches.

● SINKER CUP

Close sinker cams with fixed pushing procedure.

● MAIN KNITTING POSSIBILITIES

Single or double welt knitted with jacks by means of several selections with knitted, floated or laid-in elastic Yarn. With 8 feeds on the same course: 3 technical ways, plus fishnet or anti-drop stitch structures; pattern with floated yarn (or sharp pattern) in 2 technical ways (knit and miss).

Possibility of inlaid knit work on all feeds. From 14" to 15" the 4th and 8th feed are missed of transfer cam.

Optional: n.4 extractable knit cams to work at 4 feeds on the same course by using 3 technical ways plus 2 colours on the ground yarn and fishnet or antidrop stitch.

Structures, 3 technical ways plus pattern with floated yarn (or sharp pattern) plus fishnet or anti drop stitch structures. 2 Technical ways plus 3 colours on the ground yarn and fishnet or anti-drop stitch.

On 14" and 15" the 4th and 8th feed are without colour yarnfinger.

● YARN FEEDERS

n° 10 B TSR ULTRAFEEDER 2 (2 for the elastic board) plus n.8 LGL Santoni ECOPOWER feeders with serial connection enabling visualization on board display of yarn absorption. Optional: B TSR ULTRAFEEDER 2 ; MEMMINGER SFE - ELAN ; LGL Santoni ECOPOWER and/or ECOPOWER ATTIVO; Dinema PLUS.

● YARN SENSORS

N° 43 optical serial sensor.

● CREEL

Complete back creel. Option: creel with pneumatic threading or closed creel for cotton yarn.

➤ **LUBRICATION**

Pneumatic pump with oil recycle.

➤ **CYLINDER ROTATION**

Brushless motor and electronic handwheel for manual control.

➤ **ELECTRONIC CONTROLLER**

HIE Electronic (High Integration Electronic) with integrated board from Dinema, for the serial checking of all exit, protected from short circuit. RAM memory capacity 6 MB.

➤ **MACHINE KEYBOARD**

Color keyboard with monochromatic display backlighted.

➤ **PROGRAMMING**

Software Diagraph 3 plus including Atlas, Quasar, Photon, Galois. The programs can be transferred to the machine by FDU-2/3, by USB key or by cable directly from the PC.

➤ **CONSUMPTION**

Absorbed power from 14" to 16": fans 4,1 kW (at 400V / 50Hz) or 5,1 kW (at 220V / 60Hz); motor 2,2 kW.
Absorbed power from 17" to 22": fans 4,4 kW (at 400V / 50Hz) or 5,6 kW (at 220V / 60Hz); motor 2,2 kW.
Compressed air: 50 liters/min at 6 bar.

➤ **WEIGHT**

Approx. Kg 620 / 770.

➤ **PRODUCTION**

SEAMLESS-WEAR, UNDERWEAR, OUTERWEAR, SWIMWEAR, SPORTSWEAR (possibility to use a wide range of yarns including bared and covered elastomer).

➤ **NORMATIVE**

The machine meets the CE normative and is UL compatible.

TECHNICAL DRAWING AND SIZE

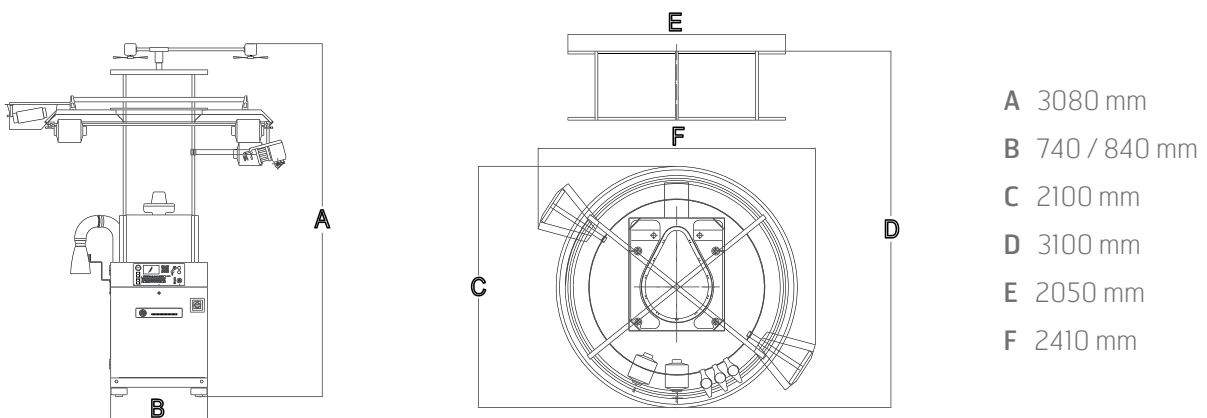

DISCLAIMER:

Technical data given in this brochure are for information only. Santoni S.p.A. reserves the right to modify the machine features without forewarning and without the obligation to apply any modification to the machines already installed. Pictures are exemplifying and have not to be regarded as a reference.

Santoni is recommending needles from
GROZ-BECKERT®



SANTONI SPA

Via Carlo Fenzi, 14 - 25135 Brescia - Italy
Tel. +39 030 376711 Fax +39 030 3366478
P.IVA e CF: IT 00273280172
www.santoni.com